

## CX Technical Data.

Low level Order Picker.



# CX Technical Data.

This specification sheet to VDI Guidelines 2198 or 3597 gives the technical figures for the standard truck only. Different tyres, other masts, additional equipment etc. could give different figures.

Characteristics	1.1	Manufacturer		STILL			
	1.2	Manufacturer's		CX 20			
	1.3	Power supply (electric, diesel, petrol, gas, mains electric)		Electric			
	1.4	Type of control (hand, pedestrian, stand-on, rider seated, order picker)		order picker			
	1.5	Capacity / load	Q	kg	2000		
	1.6	Nominal load centre	c	mm	1200		
	1.8	Load distance	x	mm	1615		
	1.9	Wheelbase	y	mm	2843 <sup>1</sup>		
	Weight	2.1	Weight (incl. Battery)		kg	1145	
2.2		Axle loadings laden	drive end / load end	kg	1250 / 1895		
2.3		Axle loadings unladen	drive end / load end	kg	880 / 265		
Wheels   Tyres	3.1	Tires (rubber, Vulkollan, pneumatic, polyurethane)			Vulkollan		
	3.2	Tire size	drive end	mm	Ø 250 x 100		
	3.3	Tire size	load end	mm	Ø 85 x 80		
	3.4	Castor wheels (size)		mm	Ø 150 x 50		
	3.5	Wheels, number (x=drive wheel)	drive end / load end			1 x 1 / 4	
	3.6	Track width	drive end	b <sub>10</sub>	mm	475	
	3.7	Track width	load end	b <sub>11</sub>	mm	348	
Dimensions	4.4	Lift height		h <sub>3</sub>	mm	130	
	4.8	Seat / Platform height		h <sub>7</sub>	mm	135	
	4.9	Height of tiller in drive position	min. / max.	h <sub>14</sub>	mm	1165	
	4.15	Forks height lowered		h <sub>13</sub>	mm	85	
	4.19	Overall Length		l <sub>1</sub>	mm	3805 <sup>1</sup>	
	4.20	Length to front face of forks		l <sub>2</sub>	mm	1425 <sup>1</sup>	
	4.21	Overall width		b <sub>1</sub>	mm	800	
	4.22	Forks dimensions		s / e / l	mm	61 / 172 / 2390	
	4.25	Forks external width		b <sub>5</sub>	mm	520	
	4.32	Floor clearance, centre of wheelbase		m <sub>2</sub>		24	
4.34	Working aisle width for pallets 800 x 1200 lengthwise (b <sub>12</sub> x l <sub>6</sub> )		A <sub>st</sub>	mm	4127 <sup>1</sup>		
4.35	Outer turning radius		W <sub>a</sub>	mm	3046 <sup>1</sup>		
Performances	5.1	Travelling Speed	laden / unladen	km / h		9 / 12,5	
	5.2	Lifting Time	laden / unladen	s		2.1 / 1.7	
	5.3	Lowering Time	laden / unladen	s		1.7 / 3.2	
	5.7	Gradeability	laden / unladen	%		6 / 6 <sup>2</sup>	
	5.9	Acceleration time (over 10 m)	laden / unladen	s		6.4 / 5.2	
	5.10	Service brakes					electromagnetic
Electric motors	6.1	Drive motor, rating S2 = 60 min		kW		3.0	
	6.2	Lift motor, rating at S3 = 15%		kW		2.2	
	6.3	Battery to IEC 254-2; A, B, C, no					IEC 254 - 2; B
	6.4	Battery voltage, capacity		K <sub>s</sub>	V / Ah		24 / 450
	6.5	Battery weight +/- 5% (dependant on manufacturer)			kg		410
	6.6	Energy consumption according to VDI cycle			kWh / h		0.99
Others	8.1	control				controller	
	8.4	Noise peak at operator's ears		dB (A)		66.5	

1) With battery tray 600 Ah: + 85 mm

2) Gradeability is limited due to truck's geometry

Values for turning radius W<sub>a</sub> for working aisle width calculation (all values in mm)

Forks length	Distance X	Battery tray	
		450 Ah	600 Ah
1190	1005	2430	2516
1450	1265	2690	2776
1650	1105	2530	2616
2150	1605	3030	3116
2390 <sup>a</sup>	1845	3270	3356
2390 <sup>b</sup>	1615	3040	3126
2900	2125	3550	3636
3100	2125	3550	3636

a) Wheelbase suitable for picking up 3 Euro pallets CROSSWAYS

b) Wheelbase suitable for picking up 2 Euro pallets LENGTHWAYS

## Truck frame.

- Reinforced at the front to act as a collision guard. The working parts of the truck are all easily accessible behind the removable front cover.

## Steering.

- Fully electric steering with automatic return to the neutral position.  
 - In the centre steering range any unintentional steering movements are electronically damped, to guarantee precise straight-ahead driving without oscillations.  
 - Automatic speed reduction when driving around curves and side mounted idler support castors give high lateral stability and reduce the effects of centrifugal force.

## CX 20 Standard version

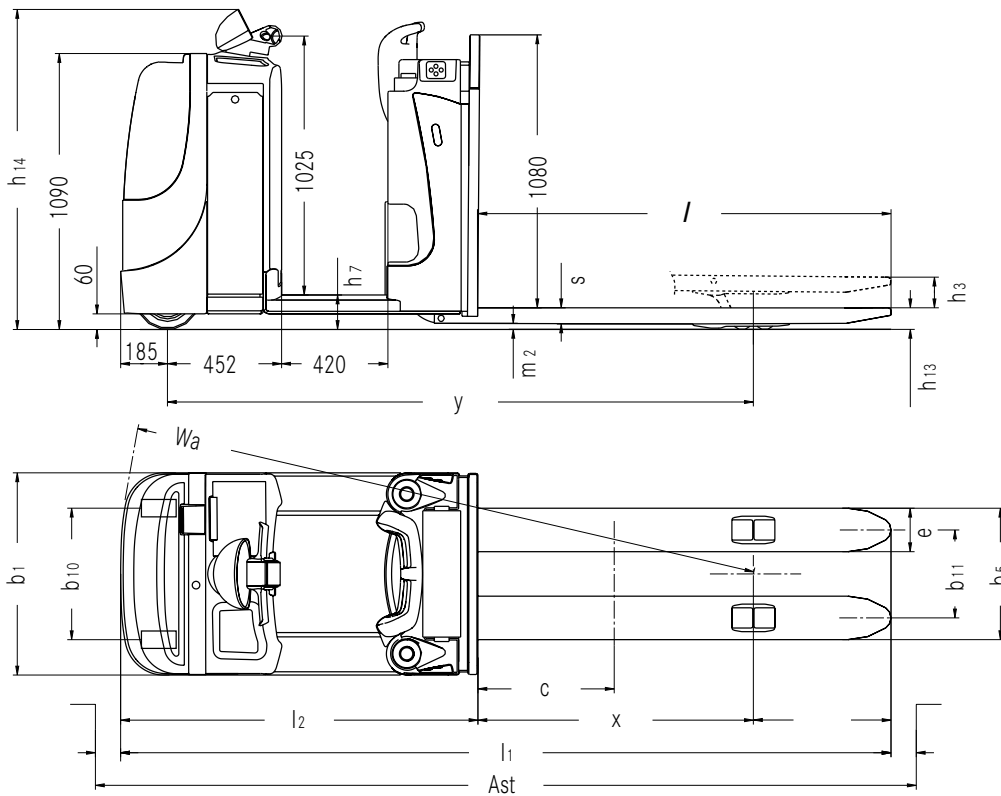

## CX 20 with platform lift (optional)

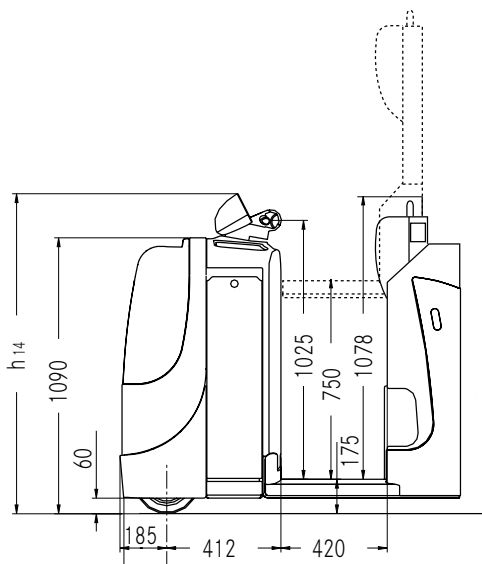

### Multi-function controls.

The new multi-function control "COCKPIT" contains all the functions for control, operation and monitoring on the CX. Thanks to the ergonomic layout of the buttons, all functions can be reached without changing the grip. The following functions are integrated in the COCKPIT:

- Driving
- Steering
- Lifting and lowering
- Work hour meter
- Discharge battery indicator
- Adjustable driving profiles
- Access control (provided as standard through coded ignition switch)
- Diagnosis (by means of service code)

In addition, the COCKPIT provides secure support whilst driving.

### Driver's stand-on platform.

- A fixed but floating (vibration-damping) stand-on platform provides optimal conditions when climbing in and out, due to the low, chamfered entry steps fitted with an anti-slip covering.
- The entire stand-on platform on the CX acts as a deadman switch.
- The back panel of the driver's platform is made of RIM, and has been ergonomically matched to the driver's needs. The padded backrest with shaped side supports offers the greatest comfort and security when driving.
- There are various storage facilities and holders for rolls of film integrated within the driver's compartment.
- A writing surface is available as standard on the CX.

## Drive.

- Powerful, economical and hence cost saving work thanks to the 3,0 kW AC-drive line.
- The latest AC-controller generation combined with STILL COCKPIT offer the possibility to adapt the truck's performances at a finger tip, switching from one motor power control mode to another.
- In "ECO" mode (button Turtle), the motor is controlled in the first range of his nominal curve, meaning by that low current draw and standard accelerations. This results in 15% more autonomy within one battery shift but same productivity as regular trucks on the market.
- In "BOOST" mode (button Hare), the controller drives the motor in his upper functional range, providing very high torque / acceleration and higher speed with load. While the autonomy remains unchanged, the productivity rise up from 25% compare to other trucks existing so far.
- Within each mode, the drive profile can be further fine tuned (speed, acceleration, braking) to match perfectly the application's environment or driver's wishes.
- Thanks to the speed sensor looping back to the controller, the EXU-S will start smoothly and accelerate evenly up to maximum travel speed, independently from the load on forks.
- The truck is braked when driving by releasing the COCKPIT drive switch or by plugging. The AC-motor acts as a generator and is used to recover energy when braking.
- When starting on a gradient, or if the drive switch is released or put into neutral, the controller would immediately detect any reversing and activate the disk brake to prevent any uncontrolled rolling back.

## Hydraulic system.

- A compact pump and motor unit with a built in oil tank, solenoid valve and maximum pressure valve operates on the lift cylinder with lift cut-out.

## Brake system.

The brake system uses two independent systems. These are

- "Soft" braking with energy recovery, activated by releasing the drive switch.
- Emergency braking takes place when the push-button in the COCKPIT is actuated.
- Driving is only possible when the driver is on the stand-on platform.

## Battery.

- The battery is easily accessible, and for two or three shift operation can be changed with a hoist or from the side with integral roller tracks.
- Batteries with a capacity up to 450 Ah or 600 Ah respectively can be accommodated in two different battery trays.

## Platform lift.

If products have to be picked at the second level several times an hour.

- With a lifting range of 750 mm it is possible to achieve a platform height of 930 mm (i.e. a picking height of 2,530 mm) above the floor.
- Lifting and lowering by means of two foot-operated buttons integrated in the platform.
- The floating platform mounting absorbs vibrations, reducing the physical stress on the driver.

## Options.

- Unique modular accessory system thanks to multi-functional frame bar (front and rear).
- Adjustable A4 writing surface.
- Prepared for data terminal.
- Additional mounting system for accessories of all types (on request).
- Pedestrian operation through butterfly switch on the COCKPIT and / or through buttons on the backrest.
- Various speed regulators.
- High load backrest.
- Cold store version.
- Battery tray for 600 Ah battery.
- If required, the second order picking level can be reached using the folding step.

## Safety.

- Trucks are built to the EC Guidelines 98 / 37 and carry the CE symbol.
- Still is certified to ISO 9001.

For further information on the CX  
please visit: [www.still.de/CX](http://www.still.de/CX)

STILL GmbH  
Berzeliusstrasse 10  
D-22113 Hamburg  
Telephone: +49 (0)40 / 73 39-0  
Telefax: +49 (0)40 / 73 39-16 22  
info@still.de  
www.still.de

Achieve more.