

EXU Technical data.

Low lift pallet truck.



EXU Technical data.

Characteristics	1.1	Manufacturer			STILL	STILL		
	1.2	Manufacturer's model designation			EXU 16	EXU 18		
	1.3	Power supply (electric, diesel, petrol, gas, mains electric)			Electric	Electric		
	1.4	Type of control – hand, pedestrian, stand-on, rider seated, order picker)			Pedestrian	Pedestrian		
	1.5	Carrying capacity / load	Q	kg	1600	1800		
	1.6	Load centre	c	mm	600	600		
	1.8	Load distance	x	mm	1028	1028		
	1.9	Wheelbase	y	mm	1426	1426	1468	
	Weights	2.1	Weight (inc. battery)		kg	444	484	514
2.2		Axle loading laden	drive end / load end	kg	757 / 1287	825 / 1459	912 / 1602	
2.3		Axle loading unladen	drive end / load end	kg	346 / 98	378 / 106	401 / 113	
Wheels Chassis	3.1	Tyres (rubber, Vulkollan, pneumatic, polyurethane)			Vulkollan	Vulkollan		
	3.2	Tyre size	drive end	mm	Ø 230x75	Ø 230x75		
	3.3	Tyre size	load end	mm	1x Ø 85x100	2x Ø 85x80		
	3.4	Support roller size		mm	2x Ø 125 x40	2x Ø 125 x40		
	3.5	Wheels – number (x = drive wheel)	drive end / load end		1x-2 / 2	1x-2 / 4		
	3.6	Track width	drive end	b ₁₀	mm	469	469	
	3.7	Track width	load end	b ₁₁	mm	388	388	
Basic dimensions	4.4	Lift		h ₃	mm	130	130	
	4.9	Tiller height in drive position	min. max.	h ₁₄	mm	740 / 1230	740 / 1230	
	4.15	Fork height lowered		h ₁₃	mm	85	85	
	4.19	Overall length unladen		l ₁	mm	1743	1743	1785
	4.20	Length inc. fork back		l ₂	mm	553	553	595
	4.21	Overall width		b ₁	mm	720	720	
	4.22	Fork dimensions		s / e / l	mm	55 / 172 / 1190	55 / 172 / 1190	
	4.25	Overall fork width		b ₅	mm	560	560	
	4.32	Floor clearance, centre of wheelbase		m ₂	mm	30	30	
	4.34	Working aisle width for pallet 800 x 1200 lengthways (b ₁₂ x l ₂)		A _{st}	mm	1991	1991	2033
4.35	Turning radius		Wa	mm	1619	1619	1661	
Performance data	5.1	Travel speed	laden / unladen	km / h	6.0 / 6.0	6.0 / 6.0		
	5.2	Lifting time	laden / unladen	s	2.2 / 1.8	2.3 / 1.8		
	5.3	Lowering time	laden / unladen	s	1.7 / 2.4	1.7 / 2.4		
	5.8	max. gradeability kB 5	laden / unladen	%	10 / 20	10 / 20	10 / 20	
	5.9	Acceleration time (over 10 m)	laden / unladen	s	8 / 7	8 / 7	8 / 7	
	5.10	Service brake				electro-magnetic	electro-magnetic	
E-Motor	6.1	Drive motor, Rating S2 = 60 min		kW	1,2	1,2		
	6.2	Hoist motor, Rating at S3 = 15%		kW	2,2	2,2		
	6.3	Battery to DIN 43531 / 35 / 36; A, B, C, no			nein	nein	IEC 254-2; B	
	6.4	Battery voltage, rated capacity K ₅		V / Ah	24V / 160Ah	24V / 180Ah	24V / 240Ah	
	6.5	Battery weight +/- 5% (dependent on make)		kg	155	195	220	
	6.6	Energy consumption to VDI cycle		kWh / h	0,35	0,37	0,37	
Other	8.1	Drive control			pulse control	pulse control		
	8.4	Sound level, at driver's ear		dB (A)	68	68		

Optional hinged platform (rider/pedestrian)

1.2	Manufacturer's model designation				EXU 16	EXU 18	
1.5	Carrying capacity/load	Q	kg		Option of platform not available	Option of platform not available	
2.1	Weight (inc. battery)		kg				
2.2	Axle loading	laden drive end / load end	kg				
2.3	Axle loading unladen	laden drive end / load end	kg				
4.9	Tiller height in drive position	min. max.	h ₁₄	mm			
4.19	Overall length unladen		h _{14'}	mm			
			l ₁	mm			
			l _{1'}	mm			
4.20	Length inc. fork back		l ₂	mm			
			l _{2'}	mm			
4.34	Working aisle width for pallet 800 x 1200 lengthways (b ₁₂ x l ₂)		A _{st}	mm			
			A _{st'}	mm			
4.35	Turning radius		Wa	mm			
			Wa'	mm			
5.1	Travel speed	laden / unladen	km / h				

STILL
EXU 20
Electric
Pedestrian
2000
600
1028
1468
514
912 / 1602
401 / 113
Vulkollan
Ø 230x75
2x Ø 85x80
2x Ø 125 x40
1x-2 / 4
469
388
130
740 / 1230
85
1785
595
720
55 / 172 / 1190
560
30
2033
1661
6.0 / 6.0
2.4 / 1.8
1.7 / 2.4
10 / 20
8 / 7
electro-magnetic
1,2
2,2
IEC 254-2; B
24V / 240Ah
220
0,4
pulse control
68

EXU 20-S
2000
564
934 / 1630
423 / 141
1035
675
2265
1875
1075
685
2486
2110
2114
1738
6.0 / 6.0

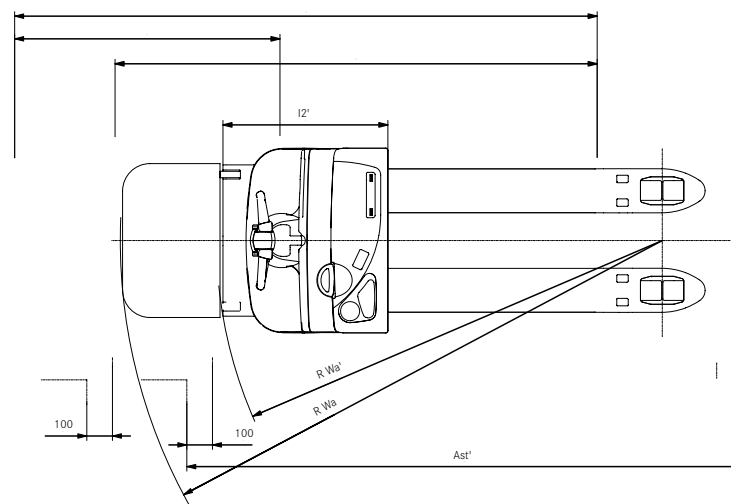
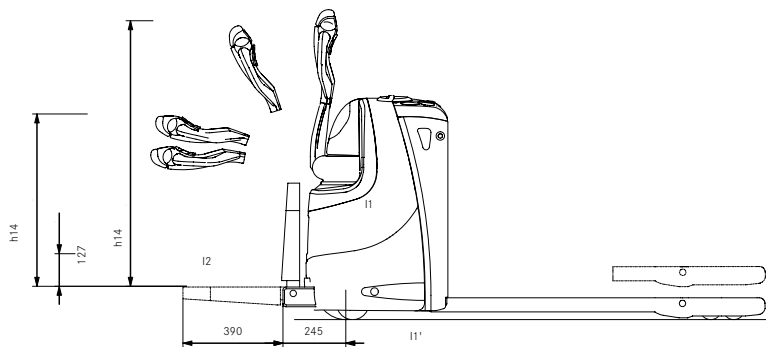
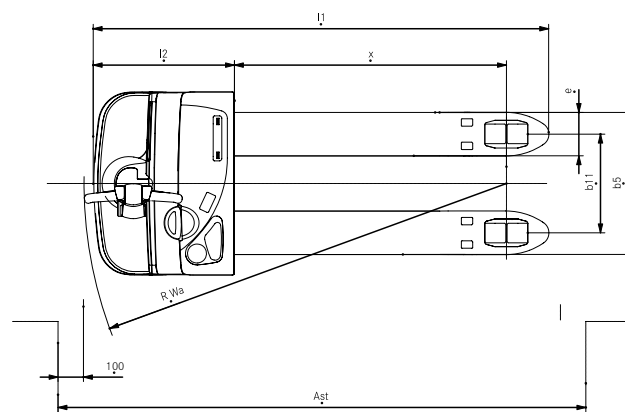
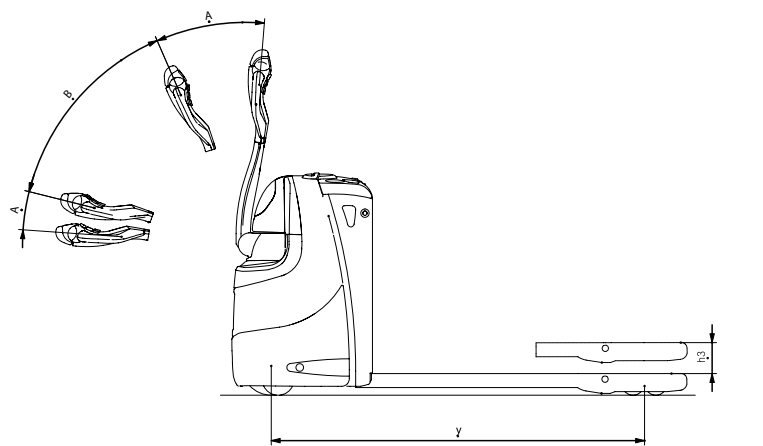

EXU Technical data.

With the new EXU low lift pallet truck, STILL presents a completely mature product that is an integral component of the Intralogistics solutions provided by STILL. Customer trials experience, thorough development and severe testing programmes have enabled us to produce a truck which is characterised by extreme robustness, superb reliability and maximum operating safety. Highest quality components further contribute to the EXU's combination of excellence. Whether in the service trades, in logistics, in light or heavy industry, the low lift pallet trucks from STILL are always ideally equipped. The EXU is equally well designed for the most difficult application conditions such as driving on ramps, being carried on lorries, working in tight conditions, or loading and unloading of lorries. The model variants of the STILL low lift pallet trucks and the many individual possible variations offer all our customers a tailor-made working unit and thus an optimal ratio between investment and benefits.

Truck frame.

- Rounded contours assist the use of the EXU on ramps and also when working in the tightest spaces e.g. on a lorry
- The floor clearance is selected so that it is easy to drive on and off difficult ramps. It also provides safety for the operator's feet
- All the covers on the truck are made of glass fibre reinforced polyurethane using a roto-moulding process and are thus extremely strong
- The very precise fit between cover and chassis guarantees a good seal against water e.g. rain
- Extremely robust forks of special steel profile feature monoblock fork tips made of steel castings. If required, 1000 kg can be lifted on one fork tip without risk
- To ease the picking up of pallets laterally, fork tips have integral skids

Steering.

- Work in the tightest spaces thanks to the low resistance tiller steering
- When released, the tiller is automatically returned to the vertical braking position by a gas strut. The gas strut ensures a damped stop

Tiller.

- The ergonomic arrangement of the controls is suitable for right or left handers. The push buttons for warning horn, lifting and lowering can be operated without changing the grip. This reduces operator fatigue
- The large sized buttons have depressions/raised areas. This means that even with gloves it is easy to "sense" the function
- The layout and the electronic controller permit simultaneous use of the controls and functions such as hoisting and driving
- Increased security for hands on the tiller thanks to the all-round hand guard and the rounded frame
- The switching elements (micro switches) and tiller PCB are in class IP 65 enclosures, and all plug connectors and cable harnesses are manufactured to IP 54, making them less susceptible to environmental factors such as rain or dust
- The anatomically shaped impact switch in the tiller head prevents the operator getting trapped even when the tiller is almost vertical. The EXU will switch automatically from forward to backward travel when the impact switch touches the operator
- High strength of the tiller head thanks to the use of glass fibre reinforced polyurethane, and a cast aluminium tiller arm

Drive.

- Comfortable, economical and hence cost saving operation thanks to the electronic controller with MOSFET technology operating on a powerful 1.2 kW shunt wound motor
- The trucks will start smoothly and accelerate evenly up to the maximum speed of 6 km/h, laden or unladen
- The truck is braked when driving by releasing the drive switch or by plugging. The motor acts as a generator and is used to recover energy when braking
- When starting on a gradient, the controller and the drive operate simultaneously to prevent any uncontrolled rolling back

Two drive programmes allow the driving characteristics to be personalised via the "Hare / Tortoise" switch, greatly enhancing convenience of operation:

- Soft acceleration/braking up to a maximum of 4 km/h offers high driving comfort - even in tight driving situations and when transporting delicate goods
- Powerful acceleration / braking up to a maximum of 6 km/h offers maximum turnaround of goods

Hydraulic system.

- A compact 2,2 kW pump and motor unit enables short lifting times even with a full load, and thus a high turnaround performance
- The pump is automatically shut off when reaching maximum lift. This reduces the energy and service costs by 10 - 20% depending on the application. The maximum pressure valve protects the truck from damage due to overload

Brake system.

The brake system uses two independent systems. These are:

- Soft braking with energy recovery which is activated by releasing the butterfly switch or by plugging (different braking characteristics, depending on the "Hare / Tortoise" driving mode selected)
- The electromagnetic disc brake system is protected against dirt ingress and acts as both safety braking system and parking brake.

Braking is automatic when the tiller is horizontal or vertical (deadman braking)



Ergonomic layout of the buttons.

Battery.

- The technology of the drive controller, and the reduced energy requirement this gives, allows the use of batteries with a lower capacity even with longer working hours
- The battery is easily accessible and can be changed using a hoist
- Two different battery trays can take batteries (wet, low maintenance or maintenance-free) with a capacity from 24V/150 Ah up to 24V/250 Ah, so that the truck can be matched optimally to the application

Support rollers.

- To take on the heaviest applications such as travel on ramps, the EXU has extremely robust support rollers (\varnothing 125 mm by 40 mm) with integral shock absorber
- These can be easily and quickly adjusted from above

Load rollers.

- Standard single rollers made of Vulkollan
- If pallets are frequently picked up from the side or if low point-loadings on the floor have to be taken into account, tandem load rollers are recommended
- For use in damp environments, watertight load rollers with stainless steel ball bearings are also available

Drive wheel.

- In Vulkollan as standard
- Due to its particularly large size (\varnothing 230 by 75 mm) it ensures excellent traction however hard the application
- The drive wheel bolts can be easily and quickly reached through an aperture in the front chassis, to allow replacement of the wheel with complete safety.

Standard equipment.

- Fork lengths of 790 mm, 990 mm, 1140 mm, 1190 mm, 1390 mm or 1590 mm (others on request)
For the EXU 20 lengths of 1790 mm and 2390 mm are available with a reinforced non-sag construction
- Fork widths 520 mm, 560 mm, or 670 mm
- 3 position switch with 2 travel modes ("Hare / Tortoise").
- Combi instrument for battery state of charge with integral hoist cut-out and work hour meter
- Integral storage compartments e.g. for pencils, drinks, and A4 documents
- Writing surface with integral paper clamp
- Glove compartment with hinged lid

Options.

- Load back rest (1200 mm and 1600 mm high).
- Positioning aids for accurately picking up pallets from the side
- Sprung hinged stand-on platform for the EXU 20 (for optimal driving comfort a shorter tiller is provided for this).
- Various materials for the drive wheel (solid rubber, non-marking, etc.)
- Integral 30 A on-board charger
- Cold store version -30°C
- Unique modular accessory system thanks to multi-functional bracket
- Adjustable A4 writing surface
- Pin Code for access control
- Prepared for a data terminal e.g. STILL MMS
- Access control management with STILL FleetManagerr

Safety.

- Trucks are built to the EC Guidelines 98/37 and carry the CE symbol
- STILL is certified to ISO 9001



Covers equipped as standard with many storage compartments.



Extremely robust fork tips made of cast steel.

EXU H Technical data.

Characteristics	1.1	Manufacturer			STILL	
	1.2	Manufacturer's model designation			EXU H	
	1.3	Power supply (electric, diesel, petrol, gas, mains electric)			Electric	
	1.4	Type of control (hand, pedestrian, stand-on, rider seated, order picker)			Pedestrian	
	1.5	Carrying capacity / load	Q	kg	2000 / 800	
	1.6	Load centre	c	mm	600	
	1.8	Load distance	x	mm	972	
	1.9	Wheelbase	y	mm	1468	
	Weights	2.1	Weight (inc. battery)		kg	670
2.2		Axle loading laden	drive end / load end	kg	984 / 1685	
2.3		Axle loading unladen	drive end / load end	kg	493 / 177	
Wheels Chassis	3.1	Tyres (rubber, Vulkollan, pneumatic, Polyurethane)			Vulkollan	
	3.2	Tyre size	drive end	mm	Ø 230x75	
	3.3	Tyre size	load end	mm	2x Ø 85x60	
	3.4	Support roller size		mm	2x Ø 125 x40	
	3.5	Wheels, number (x = drive wheel)	drive end / load end		1x-2 / 4	
	3.6	Track width	drive end	b ₁₀ mm	469	
	3.7	Track width	load end	b ₁₁ mm	388	
Basic dimensions	4.4	Lift		h ₃ mm	560	
	4.6	Initial lift		h ₅	130	
	4.9	Tiller height in drive position	min. max.	h ₁₄ mm	740 / 1230	
	4.15	Fork height lowered		h ₁₃ mm	91	
	4.19	Overall length unladen		l ₁ mm	1840	
	4.20	Length inc. fork back		l ₂ mm	646	
	4.21	Overall width		b ₁ mm	720	
	4.22	Fork dimensions		s / e / l mm	55 / 184 / 1190	
	4.25	Overall fork width		b ₅ mm	564	
	4.32	Floor clearance, centre of wheelbase		m ₂ mm	30	
Performance data	4.34	Working aisle width for pallet 800 x 1200 lengthways (b ₁₂ x l ₆)		A _{st} mm	2089	
	4.35	Turning radius		Wa mm	1661	
	5.1	Travel speed	laden / unladen	km / h	6.0 / 6.0	
	5.2	Lifting time	laden / unladen	s	2.4 / 2	
	5.3	Lowering time	laden / unladen	s	1.7 / 2.4	
	5.8	max. gradeability kB 5	laden / unladen	%	10 / 20	
	5.9	Acceleration time (over 10 m)	laden / unladen	s	8 / 7	
	5.10	Service brake			electro-magnetic	
	E-Motor	6.1	Drive motor, Rating S2 = 60 min		kW	1,2
		6.2	Hoist motor, Rating at S3 = 15%		kW	2,2
6.3		Battery to DIN 43531 / 35 / 36; A, B, C, no			IEC 254-2; B	
6.4		Battery voltage, rated capacity K ₅		V / Ah	24V / 240Ah	
6.5		Battery weight +/- 5% (dependent on make)		kg	185	
6.6		Energy consumption to VDI cycle		kWh / h		
Other	8.1	Drive control			pulse control	
	8.4	Sound level, at driver's ear		dB (A)	68	

Optional hinged platform (rider/pedestrian)

1.2	Manufacturer's model designation				EXU H
1.5	Carrying capacity / load	Q	kg		2000 / 800
2.1	Weight (inc. battery)		kg		720
2.2	Axle loading laden	drive end / load end	kg		1006 / 1713
2.3	Axle loading unladen	drive end / load end	kg		515 / 205
4.9	Tiller height in drive position	min. max.	h ₁₄	mm	1035
			h ₁₄ '	mm	675
4.19	Overall length unladen	l ₁	mm	2320	
		l ₁ '	mm	1930	
4.20	Length inc. fork back	l ₂	mm	1126	
		l ₂ '	mm	736	
4.34	Working aisle width for pallet 800 x 1200 lengthways (b ₁₂ x l ₂)	A _{st}	mm	2466	
		A _{st} '	mm	2087	
4.35	Turning radius	Wa	mm	2083	
		Wa'	mm	1659	
5.1	Travel speed	laden / unladen	km / h		6.0 / 6.0

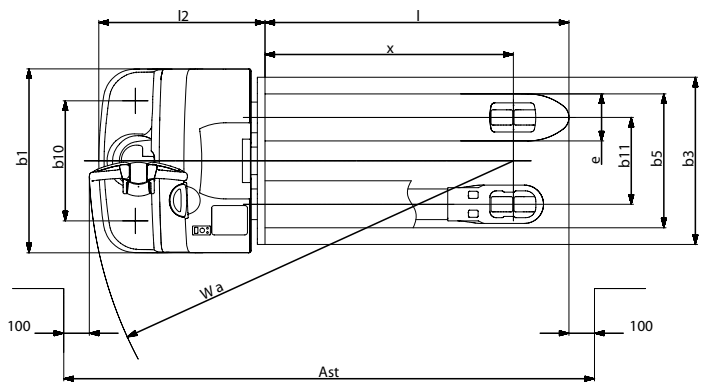
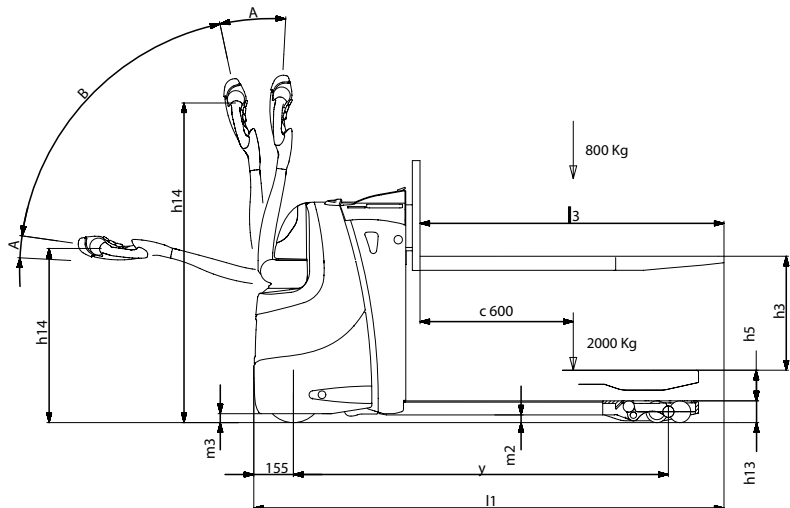

EXU H.

As a variant on the standard low lift pallet truck, the EXU H has the same product benefits as the new EXU range. In addition to this, there are important special features which make the EXU H a perfect all-round truck

- Extra order picking lift of 690 mm lift height giving a picking height of 775 mm from the floor, taking the strain off the back, and reducing fatigue levels
- Additional area of application as an order picker, mobile working table with variable working height, in the block storage or as a high lift pallet truck
- With a capacity of 2000 kg the initial lift allows the EXU H to be used as a loading and unloading truck
- The order picking lift has a residual capacity of 800 kg (at 600 mm load centre)
- Hoisting and lowering as standard from auxiliary buttons on the tiller; basic lift and order picking lift can be controlled separately.

Standard equipment.

- Standard fork lengths from 1190 mm
- Fork widths 524 mm or 564 mm
- A4 writing surface with paper clamp integrated onto the battery lid
- Battery tray can take batteries with a capacity of 24 V/200 Ah

Options for EXU H.

In addition to all the options available for the standard EXU, the EXU H can be equipped with the following further options:

- Special load back rest 800 mm high to ensure greater safety with the pallet raised
- Sprung hinged stand-on platform for transport duties over medium or longer runs
- Entry and exit rollers on the fork tips to facilitate the picking up of pallets from the side



Separate control of the order picking and initial lift.



Picking height which spares the back, thanks to the additional order picking lift.

Further information on the EXU is available
on our website: www.still.de/EXU

STILL GmbH
Berzeliusstraße 10
D-22113 Hamburg
Telefon: +49 (0)40/73 39-0
Telefax: +49 (0)40/73 39-1622
info@still.de
www.still.de

Achieve more.